

MONTAGEANLEITUNG

- | | | | |
|------------|--------------------------|------------|----------------------|
| GB | ASSEMBLY INSTRUCTIONS | CZ | NÁVOD K MONTÁŽI |
| F | INSTRUCTIONS DE MONTAGE | H | SZERELÉSI UTASÍTÁS |
| I | ISTRUZIONI DI MONTAGGIO | HR | UPUTA ZA MONTAÉU |
| NL | MONTAGEVOORSCHRIFTEN | SK | NÁVOD NA MONTÁÉ |
| E | INSTRUCCIONES DE MONTAJE | SLO | NAVODILO ZA MONTAÉO. |
| PL | INSTRUKCJA MONTAŻU | FIN | ASENNUSOHJE |
| RUS | Инструкция по монтажу | | |

PULTVORDACH EDELSTAHLTRÄGER

TYP: PT/ET 160

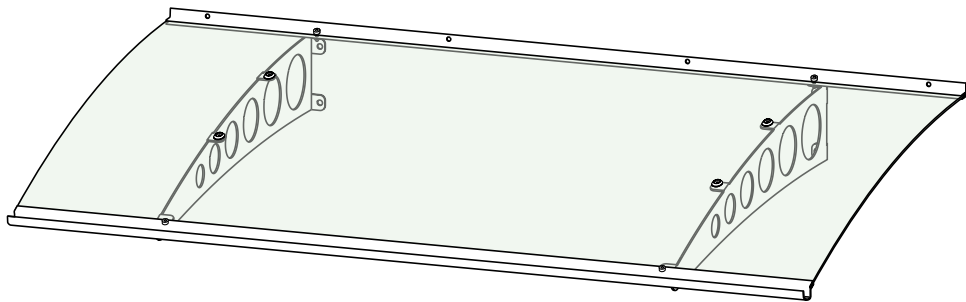





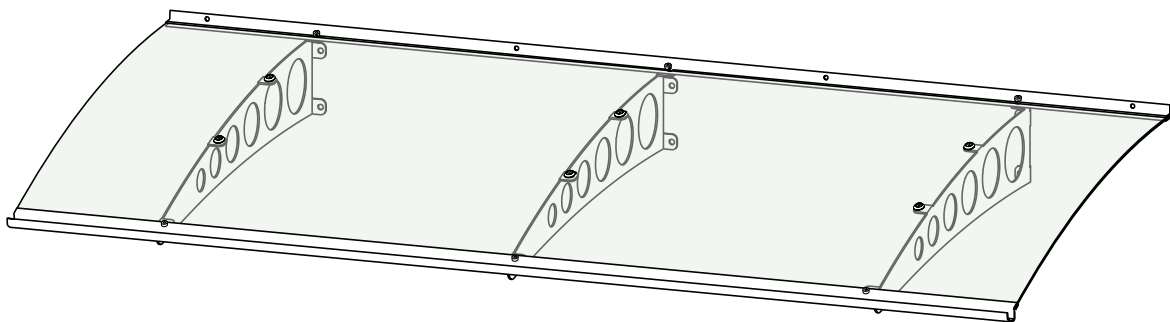

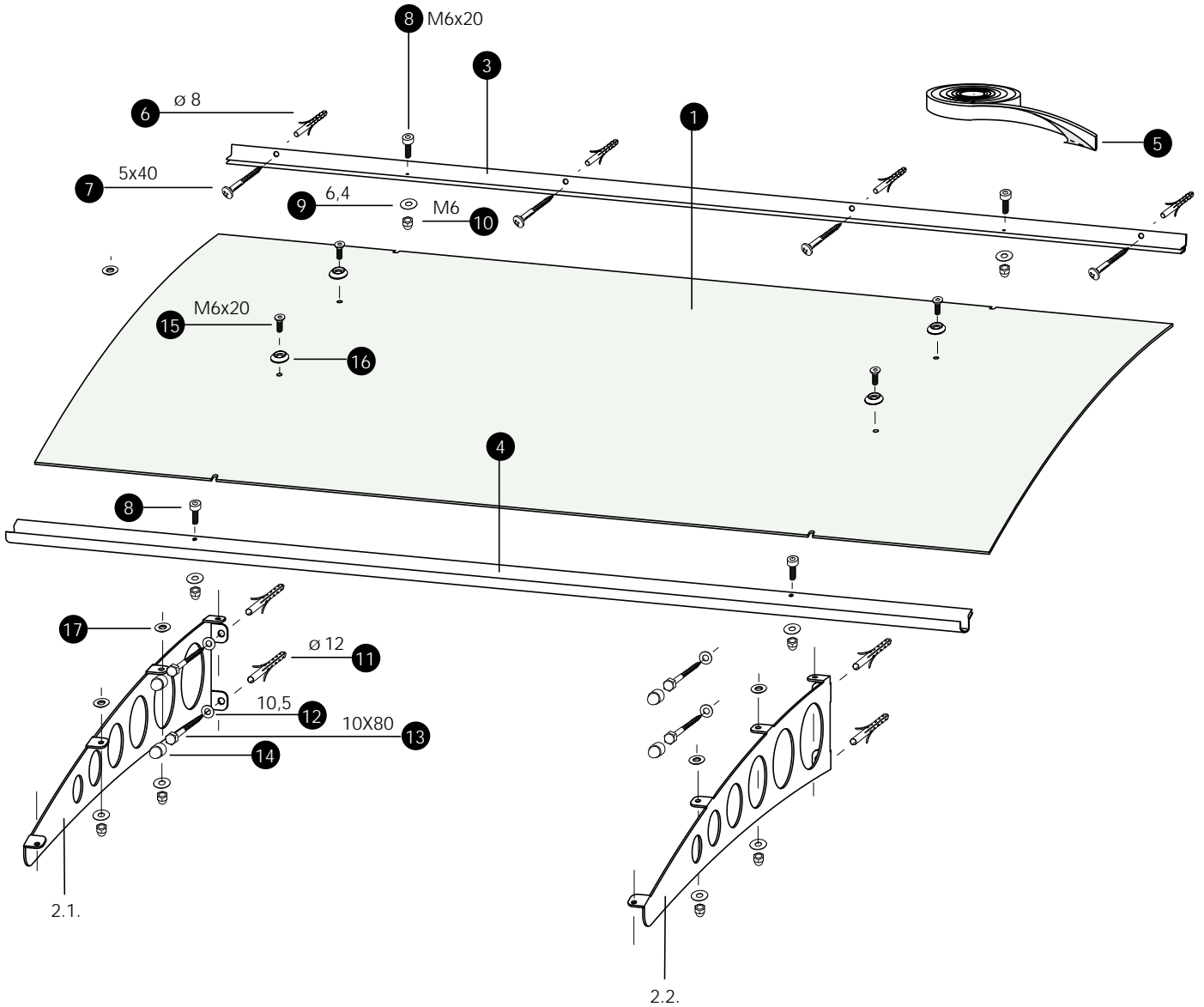
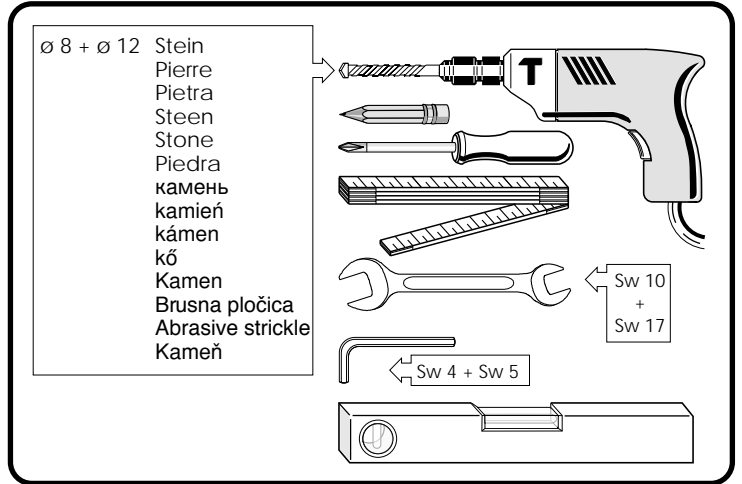
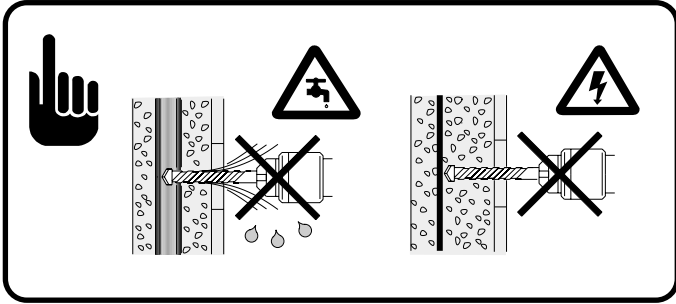

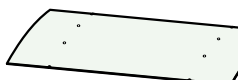

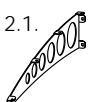
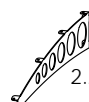







PULTVORDACH EDELSTAHLTRÄGER

TYP: PT/ET 200





Ersatzteilauftrag		Spare parts order		Commande de pieces de rechange	
PULTVORDACH EDELSTAHLTRÄGER TYP: PT/ET 160 / 200					
Nr. No. No.	Bezeichnung Designation Désignation	Artikel-Nr Article No. Article No	Stück Pieces Pièces		
			PT/ET	PT/ET	
			160	200	
1.	 Glas RVOVDP - TET0954	-----	1x	---	
1.	 Glas RVOVDP - TET1954	-----	---	1x	
2.1.	 2.1. Edelstahlträger links	400 - 4000017	1x	2x	
2.2.	 2.2. rechts	400 - 4000018	1x	1x	
3.	 Wandprofil	-----	1x	1x	
4.	 Regenrinne	-----	1x	1x	
5.	 Moosgummi	400 - 4000030	1x	1x	
6.	 Dübel ø8	4 - 0000602	4x	4x	
7.	 5x40 DIN7996	4 - 0000111	4x	4x	
8.	 M6x20 DIN7984 ZylinderKopf	4 - 0001009	4x	6x	
9.	 6,4 DIN9021	4 - 0000436	8x	12x	
10.	 Hutmutter M6 DIN1587	4 - 0001010	8x	12x	
11.	 Dübel ø12	4 - 0000603	4x	6x	
12.	 U-Scheibe 10.5 DIN125	4 - 0000431	4x	6x	
13.	 10x80 DIN571	4 - 0000131	4x	6x	
14.	 Abdeckkappe Sw 17	400 - 4000033	4x	6x	
15.	 M6x20 DIN7991 Senkkopf	4 - 0001008	4x	6x	
16.	 Rosette 6,4/22/4,9	14 - 0000050	4x	6x	
17.	 Isolierhülse 6,2/7,9	14 - 0000054	4x	6x	

KUNDENDIENST-TEL. 0 26 39 / 921 - 175 MONTAG BIS FREITAG VON 8.00 - 12.00 UHR • 13.00 - 16.00 UHR
KUNDENDIENST-FAX. 0 26 39 / 921 - 349 E-MAIL www.kundendienst@dusar.de

D	Bei Produktionsmängeln und Ersatzteilbestellungen (siehe Tabelle) bitte an den Kundenservice wenden.
GB	In case of production faults or if you wish to order spare parts (see table) please contact your local trader or the after-sales service.
F	Veillez consulter votre dépositaire ou le service après-vente pour tous défauts du produit ou pour des commandes de pièces de rechange (voir tableau).
I	Per imperfezioni dei prodotti o per ordinazione di pezzi di ricambio (vedi tabella) si rivolga, per cortesia, al suo rivenditore ossia al suo centro di assistenza.
NL	Bij fabricagefouten en onderdeelbestellingen (zie tabel) wendt U zich tot Uw handelaar respectievelijk Uw klanten service.
E	caso de defectos de producción o para efectuar un pedido de piezas de repuesto (véase tabla) sírvase consultar al servicio posventa.
P	Przy składaniu zamówień na części zapasowe prosimy zwrócić się do punktu handlowego w Państwa okolicy.
RUS	С заказами на запчасти просим обращаться в пункты продажи, которые расположены недалеко Вашего места проживания.
CZ	Při objednávání náhradních dílů se prosím obračte na prodejní oddělení v hlavním městě ve Vaší zemi.
H	A pótalkatrészek megrendelésével szíveskedjenek a legközelebbi kereskedelmi egységhez fordulni.
HR	Kod proizvodnih gređaka i kod narudžbi rezervnih djelova (vidi tablicu) molimo da se javite servisu.
SK	Prí vžrobných nedostatkoch a objednávkach náhradných dielov (vid tabuľku) sa obráťte na servisnú službu.
SLO	Prí tovarniških napakah in naročanju nadomestnih delov (poglej tabelo) obrnite se, prosim, na servis za stranke.

1.

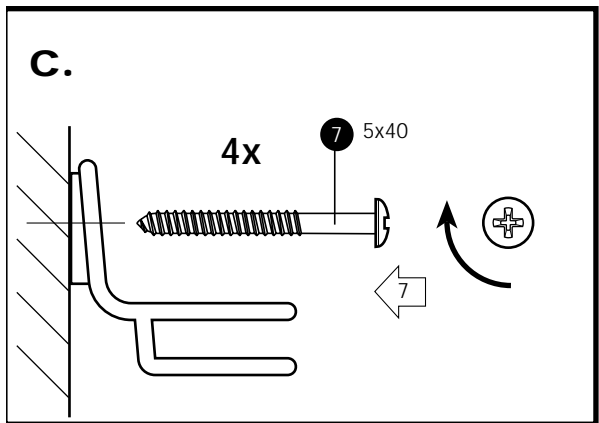
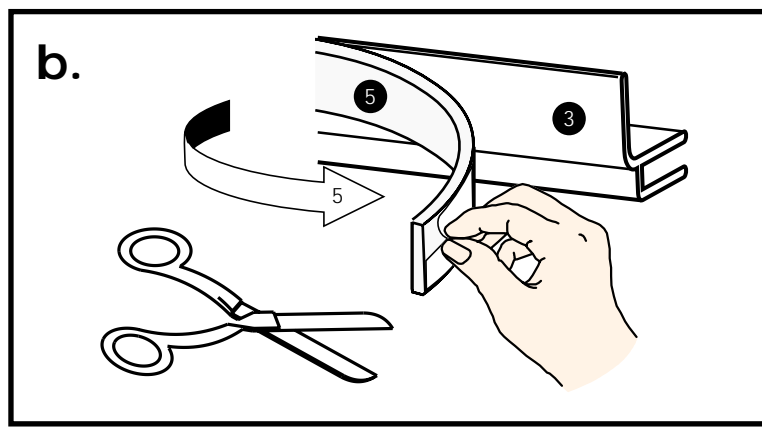
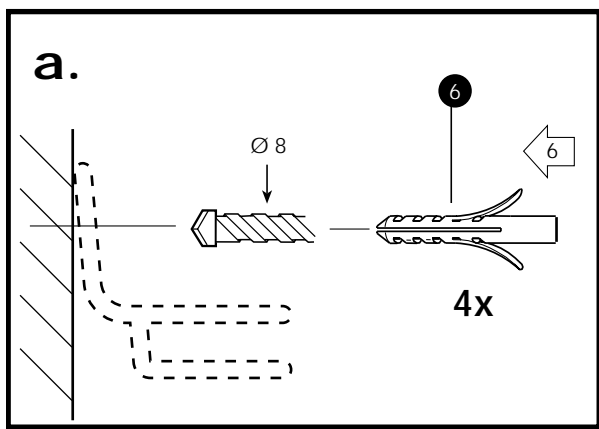
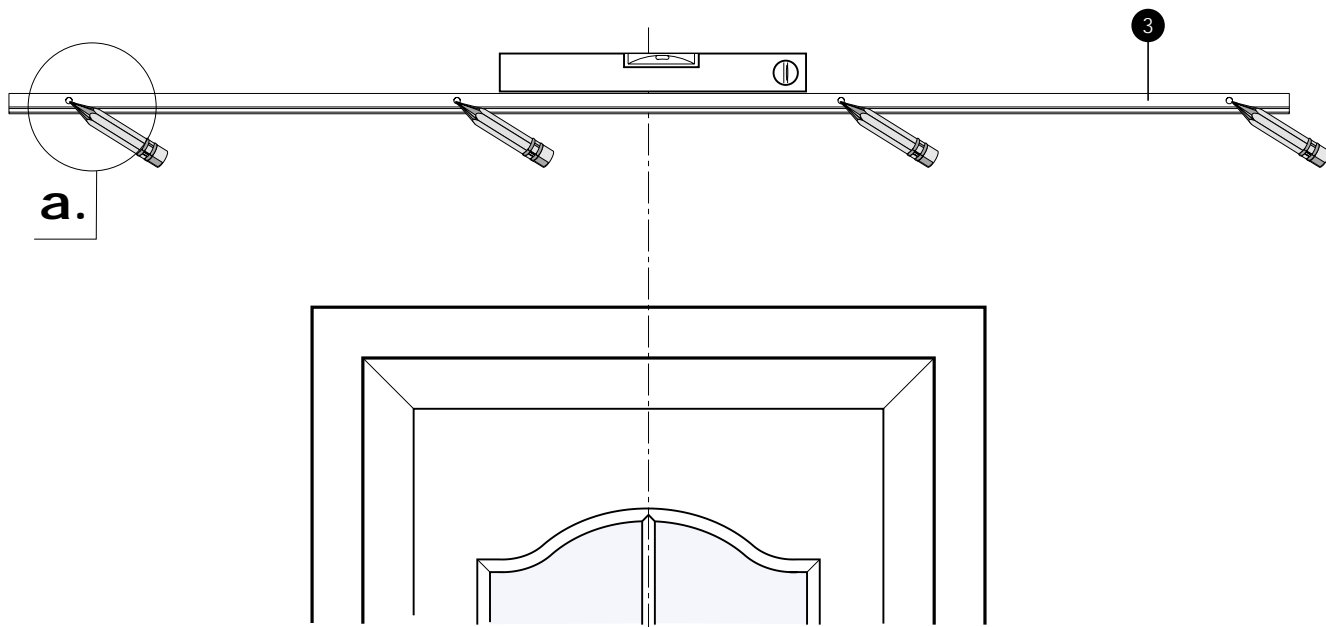

2.

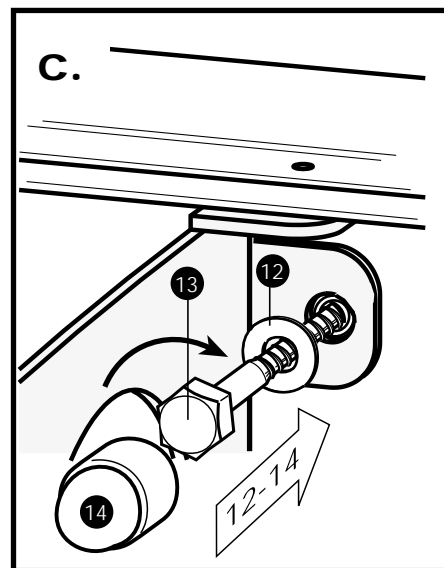
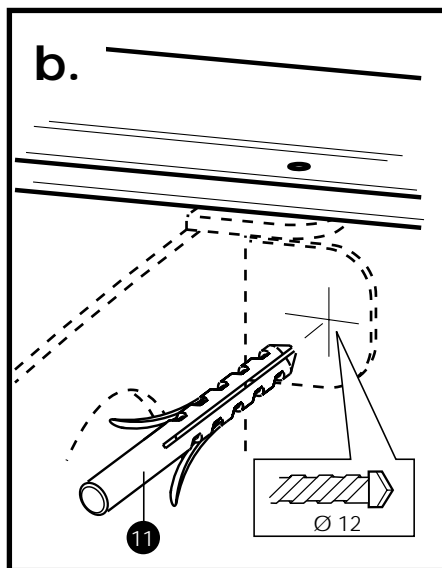
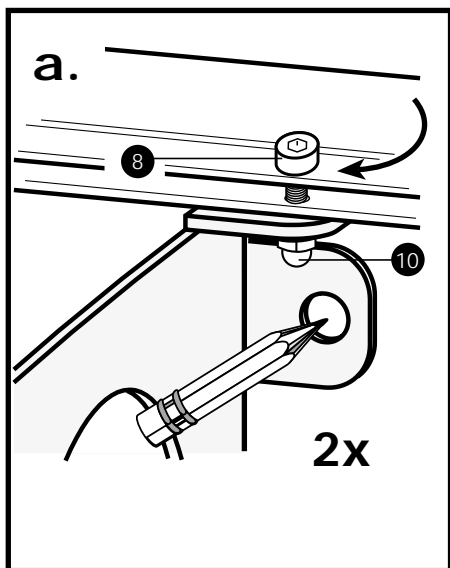
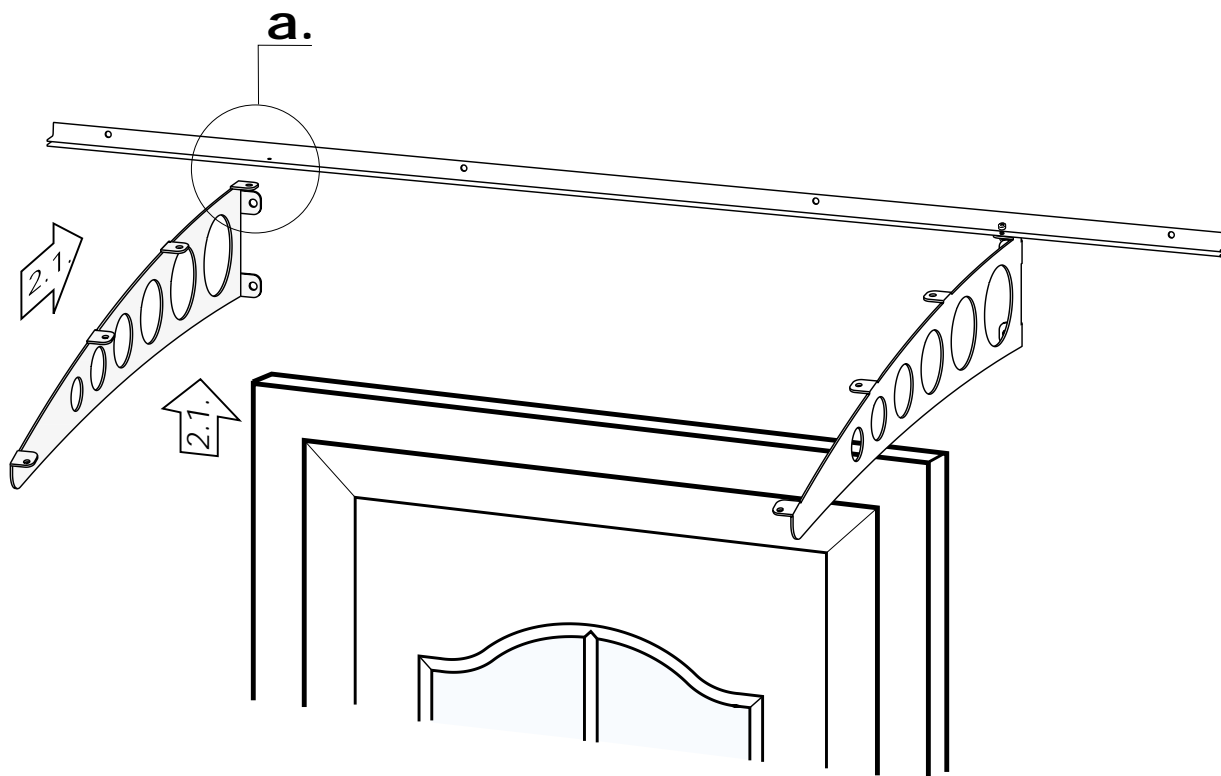

3.

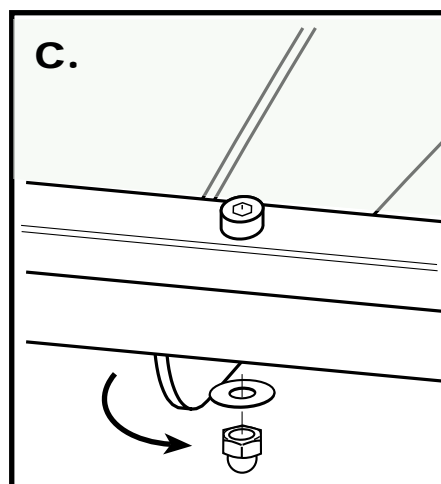
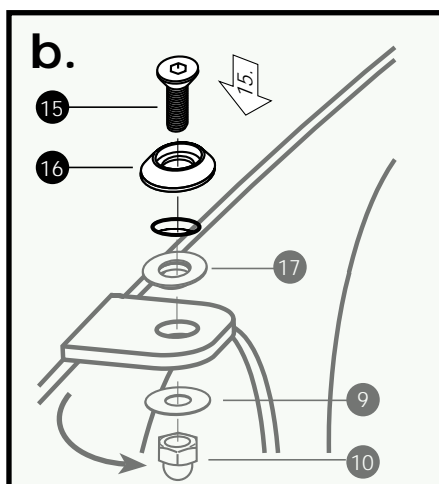
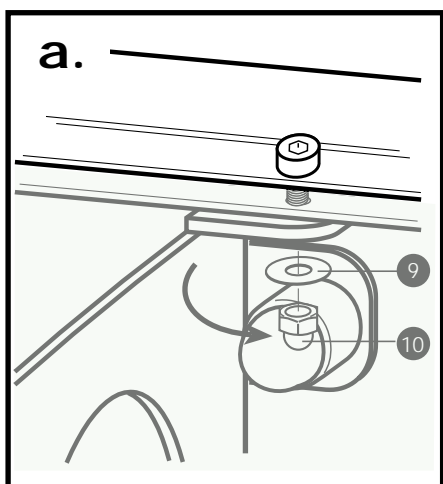
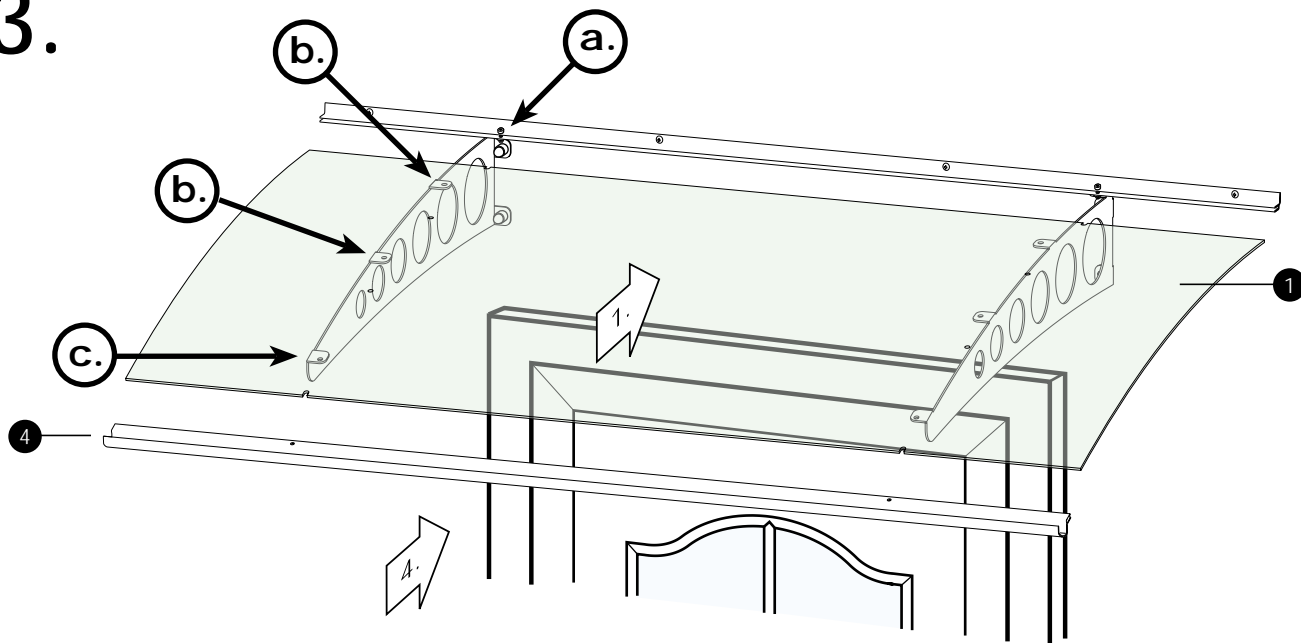

4.

