

# MONTAGEANLEITUNG

- |            |                          |            |                      |
|------------|--------------------------|------------|----------------------|
| <b>GB</b>  | ASSEMBLY INSTRUCTIONS    | <b>CZ</b>  | NÁVOD K MONTÁŽI      |
| <b>F</b>   | INSTRUCTIONS DE MONTAGE  | <b>H</b>   | SZERELÉSI UTASÍTÁS   |
| <b>I</b>   | ISTRUZIONI DI MONTAGGIO  | <b>HR</b>  | UPUTA ZA MONTAÉU     |
| <b>NL</b>  | MONTAGEVOORSCHRIFTEN     | <b>SK</b>  | NÁVOD NA MONTÁÉ      |
| <b>E</b>   | INSTRUCCIONES DE MONTAJE | <b>SLO</b> | NAVODILO ZA MONTAÉO. |
| <b>PL</b>  | INSTRUKCJA MONTAŻU       | <b>FIN</b> | ASENNUSOHJE          |
| <b>RUS</b> | Инструкция по монтажу    |            |                      |

**SERIE ATRIUM : PULTFORMVORDACH TYP: PT-120 / PT-155**  
**ATRIUM RANGE: PITCHED CANOPY TYPES: PT-120 / PT-155**

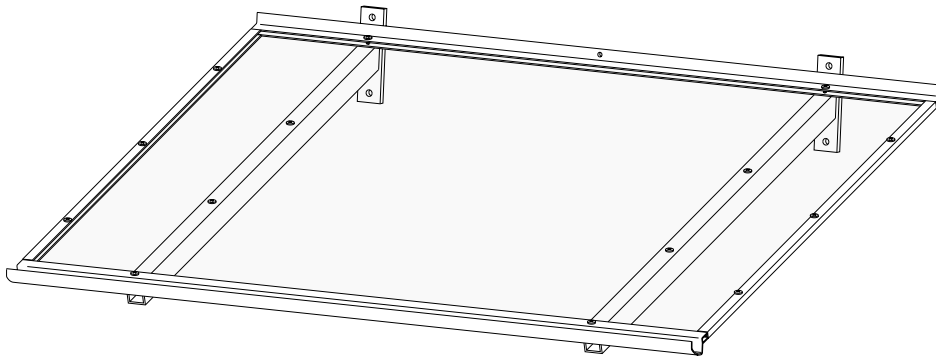

# MONTAGEANLEITUNG

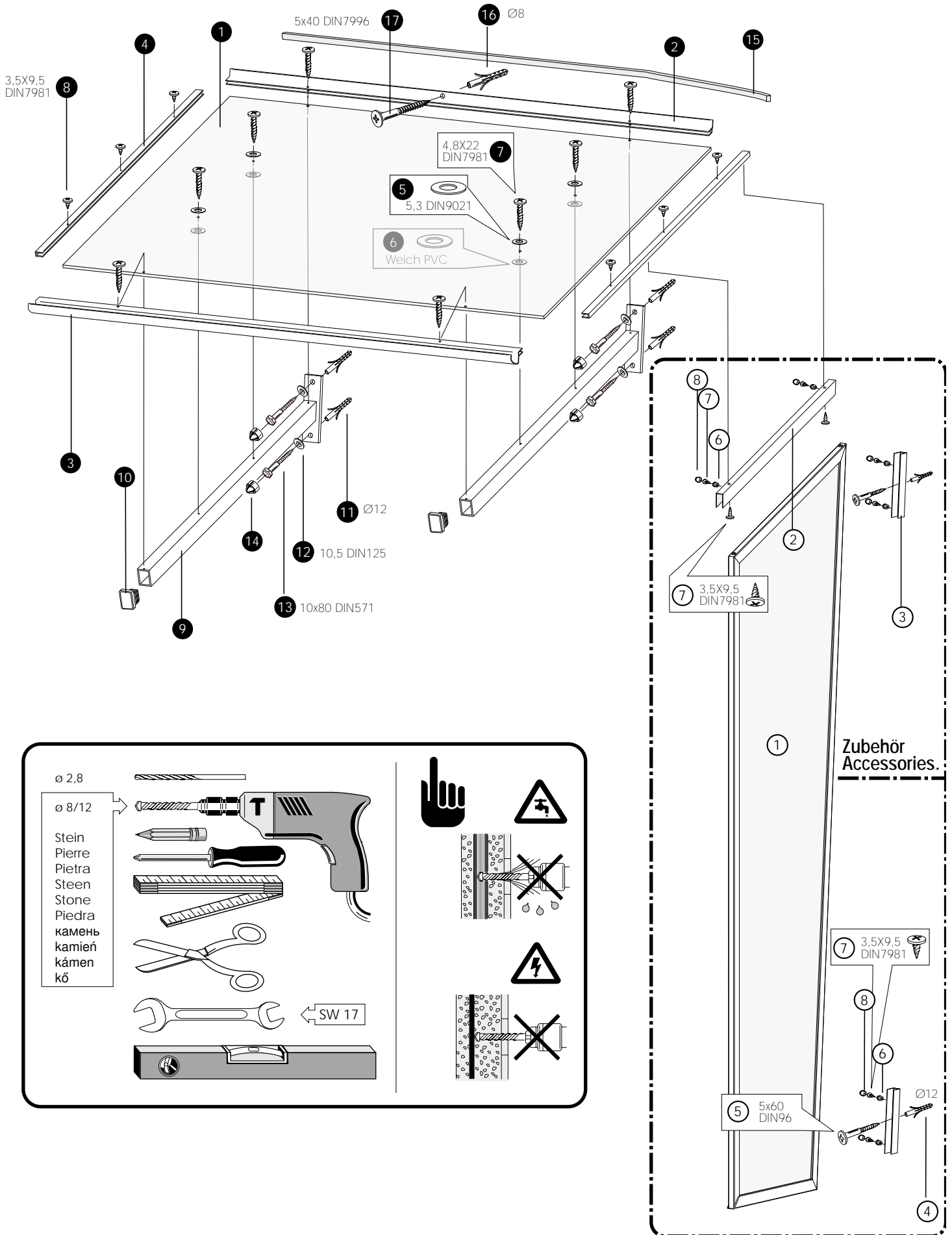

# MONTAGEANLEITUNG

1.

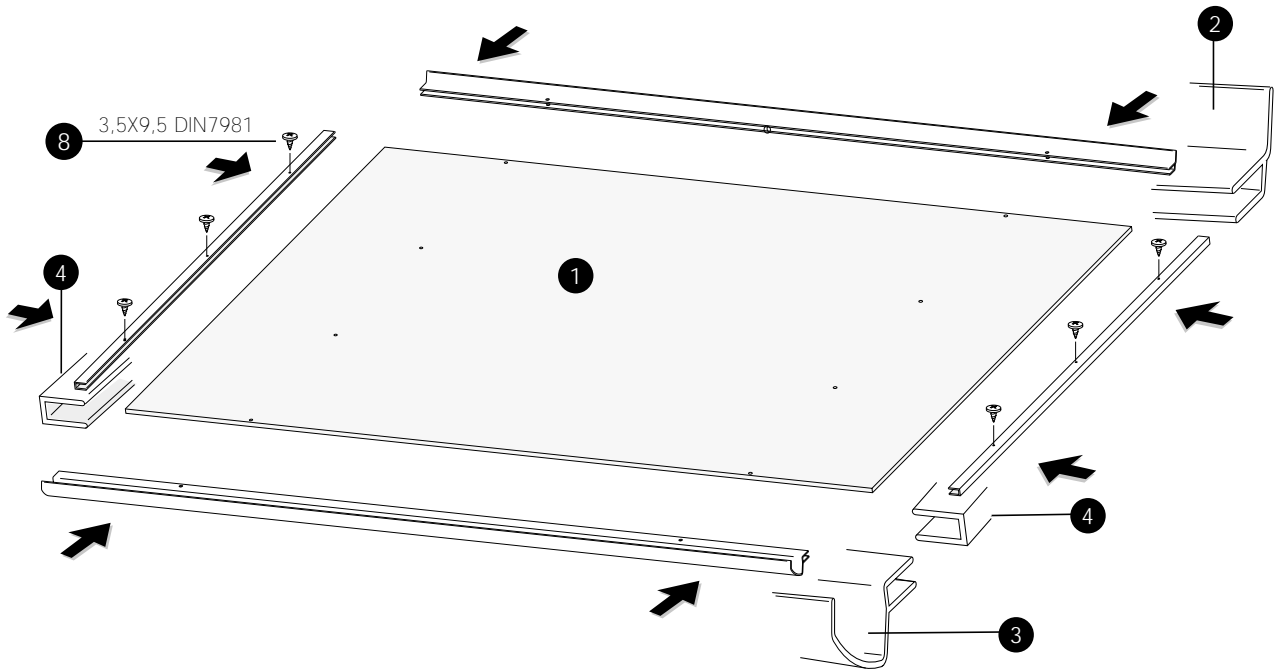

2.

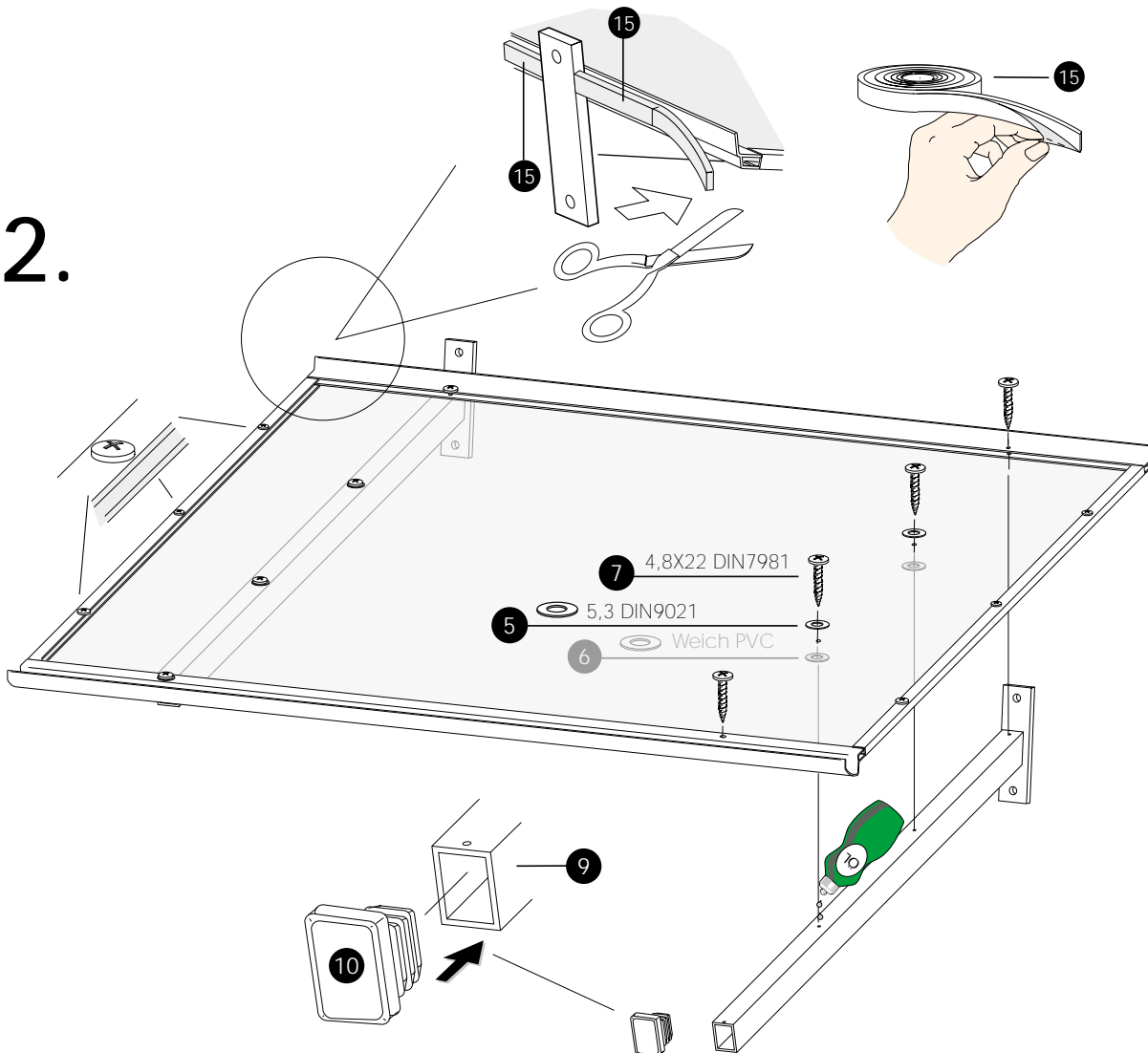

# MONTAGEANLEITUNG

3.

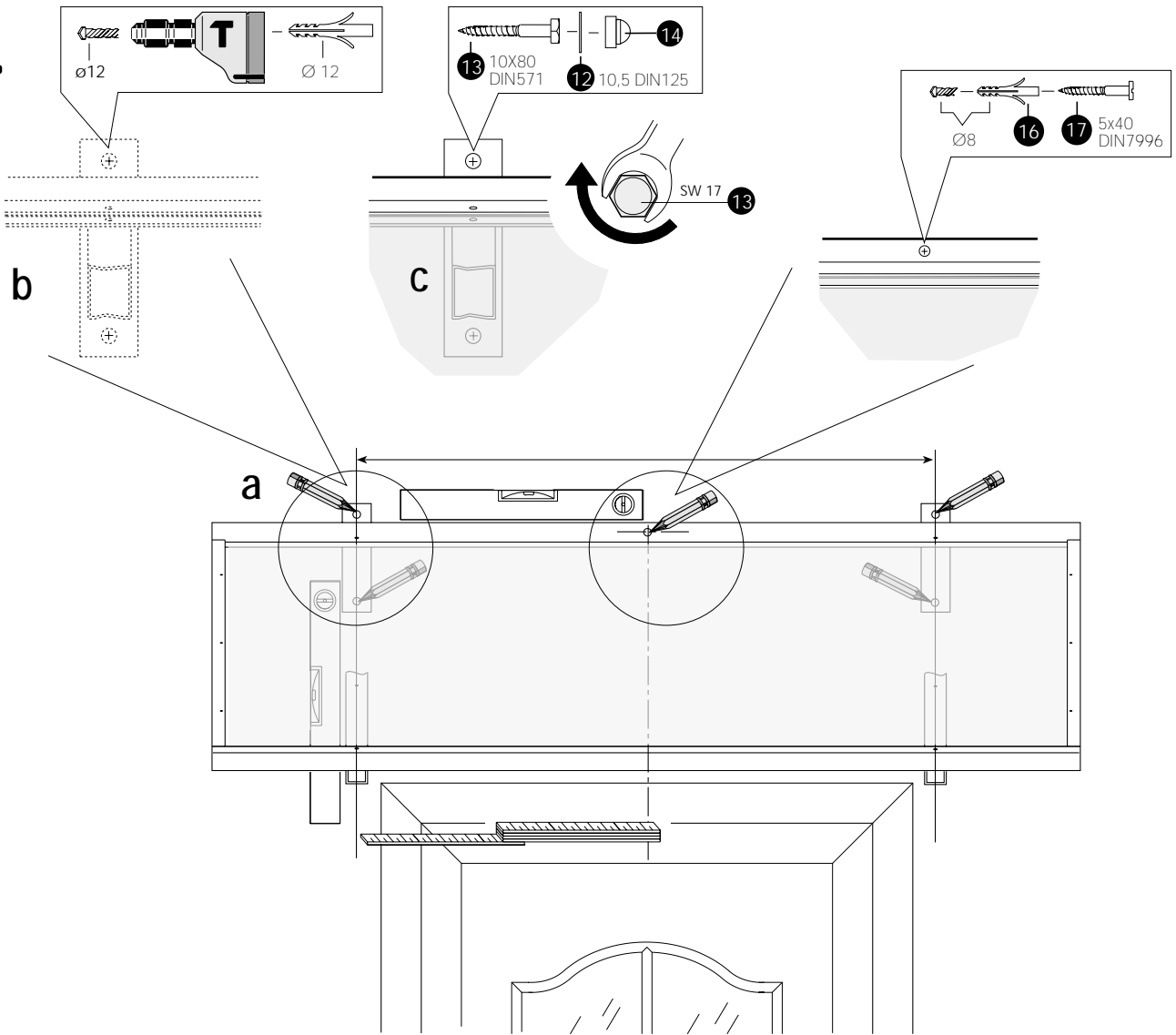



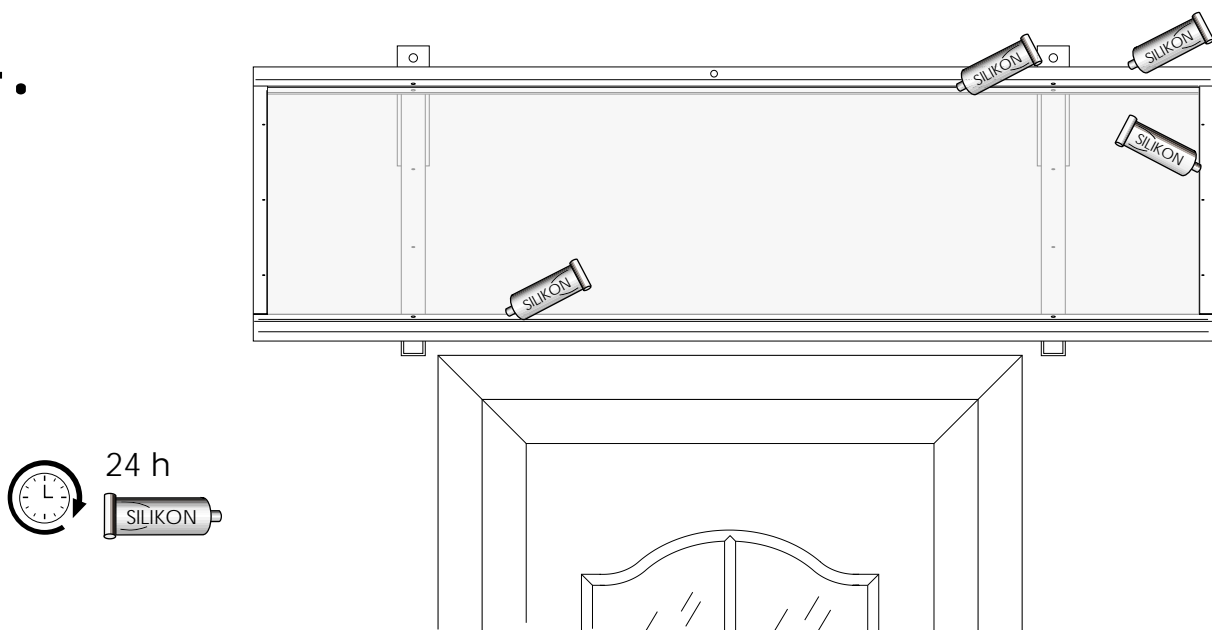



















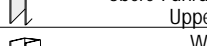

4.



## ERSATZTEILAUFRAG : SERIE ATRIUM : Pultformvordach PT-120 / PT-155

SPARE PARTS ORDER • COMMANDE DE PIÉCES DE RECHANGE • TAGLIANDO DI COMMISSIONE • ONDERDELENBESTELBON • PEDIDO DE PIEZAS DE REPUESTO  
 ЗАКАЗ ЗАПАСНЫХ ЧАСТЕЙ • ZAMÓWIENIE CZĘŚCI ZAPASOWYCH • PÓTKATRÉSZ-MEGRENDELÉS • OBJEDNÁVKA NÁHRADNÍCH DÍLU  
 NAROČILO ZA NADOMESTNE DELE • OBJEDNÁVKA NÁHRADNÍCH DIELOV • NALOG ZA REZERVNE DJELOVE • Наруджба резервних дијелова  
 Objednávka náhradných dielov • Нарočilo nadomestnih delov • VARAOSATILAUS

Nr. No. Čís. Szám átevilka C. BR. Nro	Bezeichnung Denominazione Description Название Označení Oznacitev naziv Nimitys	Description • Beschrijving • Especificación • Označenje • Megnevezés • Oznacenie	Artikel-Nr. Artículo n. Article No. Nr części Cikkszám ätevilka artikla broj proizvoda Номенклатурный номер Tuotenumero	No. d'article • Artikel-Nr. • No. de articulo • Čís. artiklu • C. tovaru • komada	Stück Pezzi Quantity Szt Kuszú количество Szállított darabszám Del Kappale	Quantité • Stuks • Piezas • Kus	Farbe • Couleur • Colore • Kleur • Colour • Color • Цвет • Kolor • Barva • Szín • Barva • Farba • boja	cm Mera	Menge • Quantità • Ordered Qty. • Cantidad de pedido • количество • заказываемых частей • Objednané množství • Ilość zamówionych części • Rendelt mennyiség • Kolicina • Mnoštvo • kolicina • Qté.cdée. • Aantal • Määrä
1	 Doppelstegglas Double-webbed glass		Abdeckung cover	400 - 4000205	1x		956		
2	 Wandanschluß-Profil Wall connection profile			1 - 0900463	1x				
3	 Wasserablauf-Profil Drainage channel profile			1 - 0900462	1x				
4	 Seiten-Profil / Side profiles			1 - 0902689	2x				
5	 5,3 DIN9021			4 - 0000411	4x		983		
6	 Weich PVC U-Scheibe / Soft PVC washers			400 - 4000460	4x		952		
7	 4,8x22 DIN7981			4 - 0000094	8x		980		
8	 3,5x9,5 DIN7981			4 - 0000013	6x		983		
9	 Rohr / Pipes			1 - 0902073	2x				
10	 Rohrkappe / Pipe caps 40x30			400 - 4000055	2x				
11	 Dübel / Plugs ø 12			4 - 0000603	4x		951		
12	 U-Scheibe / Washers A10,5 DIN125			4 - 0000431	4x		980		
13	 10x80 DIN571			4 - 0000131	4x		980		
14	 Abdeckkappe / Sealing caps Sw.17			400 - 4000033	4x				
15	 Moosgummi / Sponge rubber			400 - 4000031	1x		120		
16	 Dübel / Plug ø 8			4 - 0000602	1x		951		
17	 5x40 DIN7996			4 - 0000111	1x		980		
1	 Seitenblende Sidepanel			54025 weiss / white 54026 braun / brown	1x Zubehör / accessory		024 080		
2	 obere Führungsschiene Upper guide rail			1 - 0811099	1x Zubehör / accessory		950		
3	 Wandschiene Wall rails			1 - 0819558	2x Zubehör / accessory				
4	 Dübel / Plugs ø 8			4 - 0000602	2x Zubehör / accessory		951		
5	 5x60 DIN7996			4 - 0000113	2x Zubehör / accessory		983		
6	 Rosette / Roses			3 - 0000851	6x Zubehör / accessory		952		
7	 3,5x9,5 DIN7981			4 - 0000013	8x Zubehör / accessory		983		
8	 Abdeckkappe Sealing caps			3 - 0000850	6x Zubehör / accessory		952		

Kundendienst - Telefon 0 26 39 / 921 - 349

Kundendienst - Telefax 0 26 39 / 921 - 175

Montag bis Freitag von 8.00 - 12.00 • 13.00 - 18.00 Uhr

E-Mail kundendienst@dusar.de

- Bei Produktionsmängeln und Ersatzteilbestellungen (siehe Tabelle) bitte an den Kundenservice wenden.
- Bitte Ersatzteilauftrag benutzen. Danke!
- In case of production faults or if you wish to order spare parts (see table) please contact your local trader or the after-sales service.
- Please use the spare-parts order form. Thank you!
- Veuillez consulter votre dépositaire ou le service après-vente pour tous défauts du produit ou pour des commandes de pièces de rechange (voir tableau).
- Utilisez le bon de commande de pièces de rechange. Merci !
- Per imperfezioni dei prodotti o per ordinazione di pezzi di ricambio (vedi tabella) si rivolga, per cortesia, al suo rivenditore ossia al suo centro di assistenza.
- Per cortesia, usi il modulo per commissione pezzi di ricambio. Grazie !
- Bij fabricagefouten en onderdeelbestellingen (zie tabel) wendt U zich tot Uw handelaar respectievelijk Uw klantenservice.
- Onderdelenbestellijst gebruiken a.u.b. Dank U wel !

- En caso de defectos de producción o para efectuar un pedido de piezas de repuesto (véase tabla) sírvase consultar al servicio posventa.
- Sírvase utilizar el formulario de pedido para piezas de repuesto. ¡Muchas gracias!
- Przy składaniu zamówień na części zapasowe prosimy zwrócić się do punktu handlowego w Państwa okolicy.
- Prosimy wykorzystywać następujący formularz na części za pasowe. Dziękujemy.
- С заказами на запчасти просим обращаться в пункты продажи, которые расположены недалеко Вашего места проживания.
- Просим использовать прилагаемый бланк заказа на запасные части. Спасибо за покупку!
- Při objednávaní náhradních dílů se prosím obračtejte na prodejní oddělení v hlavním městě ve Vaší zemi.
- Následující formulář, prosím, použijte na náhradní díly. Děkujeme.

**DUSAR**<sup>®</sup>  
Ideen fürs Haus

Einer der führenden Hersteller von Duschtrennungen, Duschwannen, Badezubehör, Badewannen, Whirlpools und Vordächern.

DUSAR GMBH • INDUSTRIEGEBIET • BUCHENSTRASSE 1 • 56584 ANHAUSEN • TEL +49 (0) 2639 / 921-0 • FAX +49 (0) 2639 / 921-172

INTERNET: www.dusar.de • www.badideen.de • E-MAIL: info@dusar.de