

MONTAGEANLEITUNG

- Ⓒ GB ASSEMBLY INSTRUCTIONS
- Ⓒ F INSTRUCTIONS DE MONTAGE
- Ⓒ I ISTRUZIONI DI MONTAGGIO
- Ⓒ NL MONTAGEVOORSCHRIFTEN
- Ⓒ E INSTRUCCIONES DE MONTAJE
- Ⓒ PL INSTRUKCJA MONTAŻU
- Ⓒ RUS Инструкция по монтажу

- Ⓒ CZ NÁVOD K MONTÁŽI
- Ⓒ H SZERELÉSI UTASÍTÁS
- Ⓒ HR UPUTA ZA MONTAÉU
- Ⓒ SK NÁVOD NA MONTÁÉ
- Ⓒ SLO NAVODILO ZA MONTAÉO.
- Ⓒ FIN ASENNUSOHJE

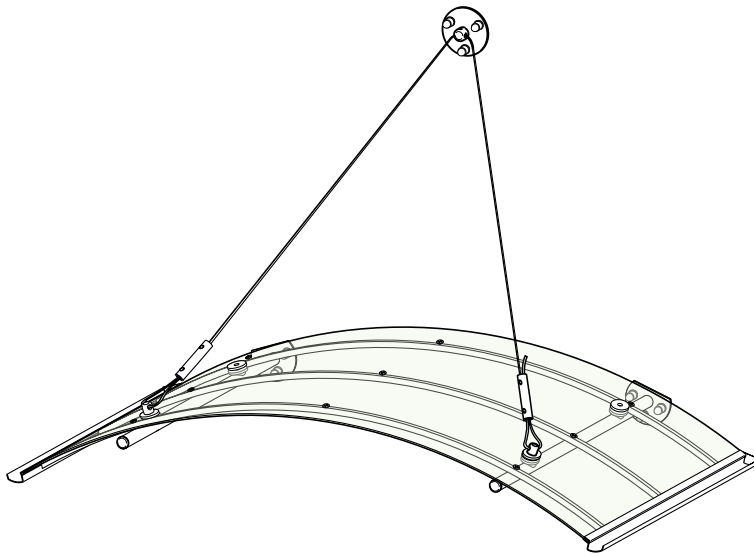

BOGENVORDACH SEIL

TYP: BV/S 160

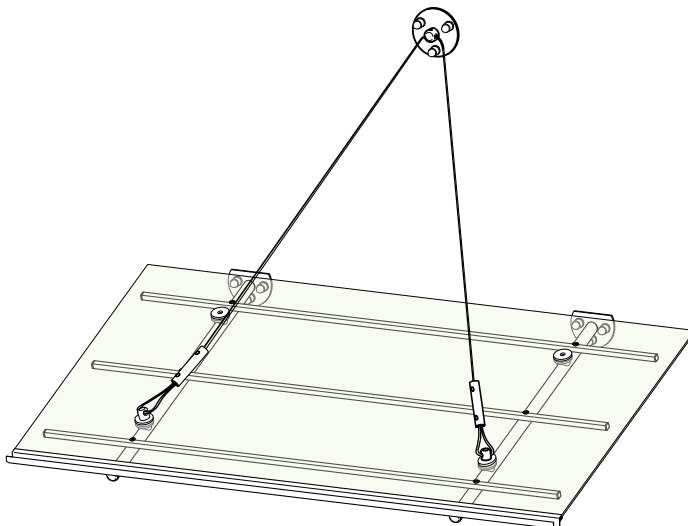

PULTVORDACH SEIL

TYP: PT/S 160

MONTAGEANLEITUNG

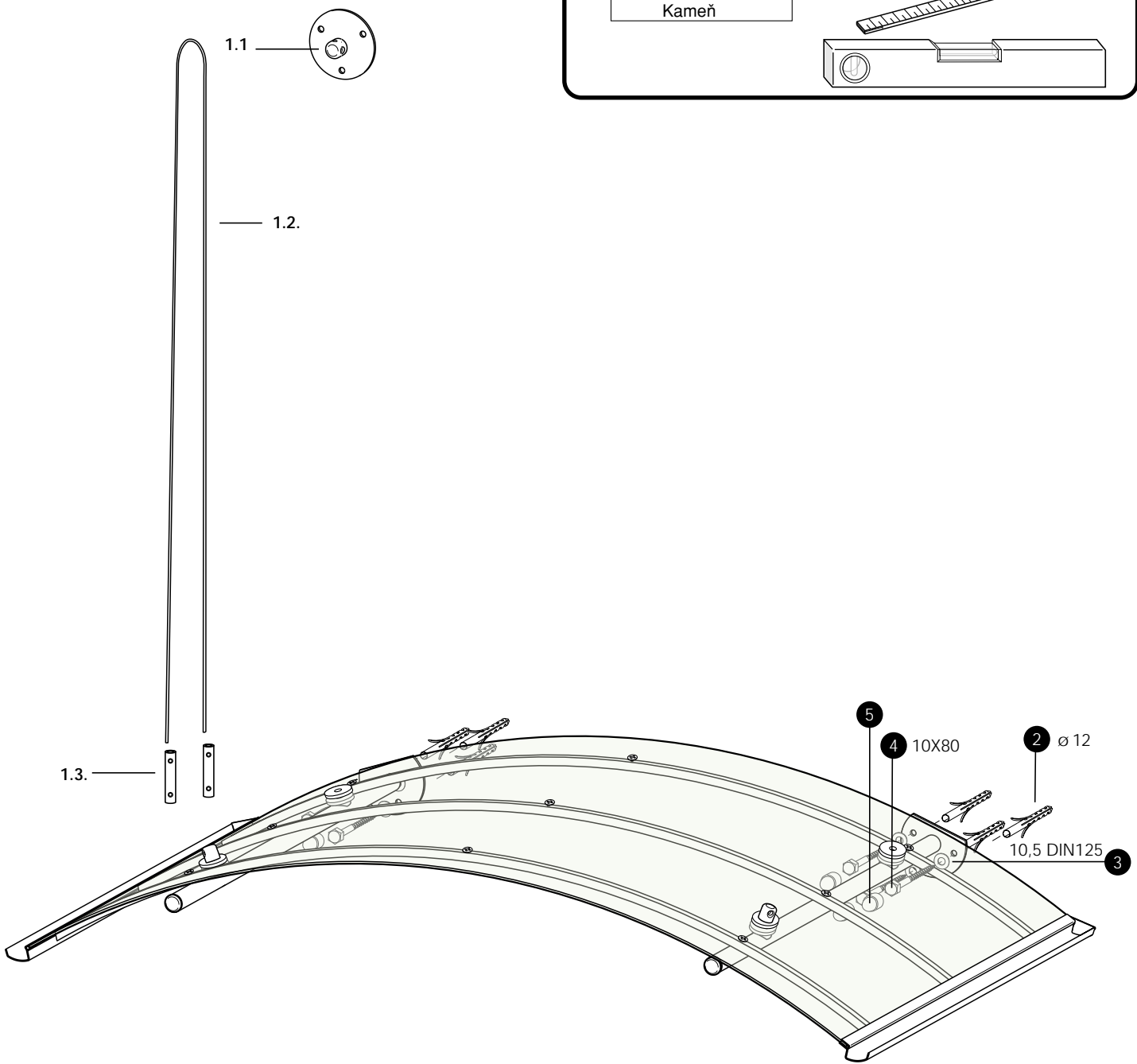
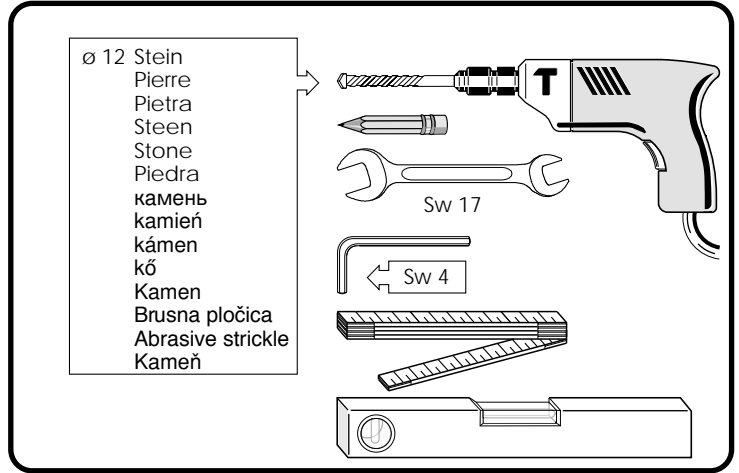
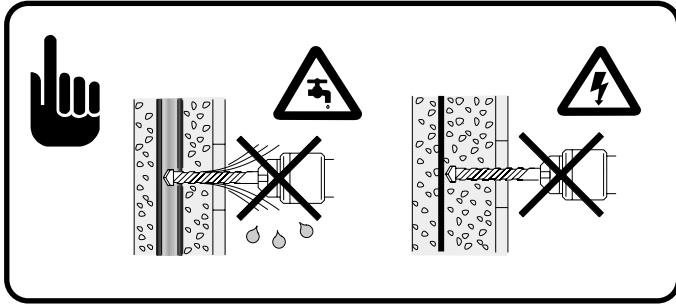

MONTAGEANLEITUNG

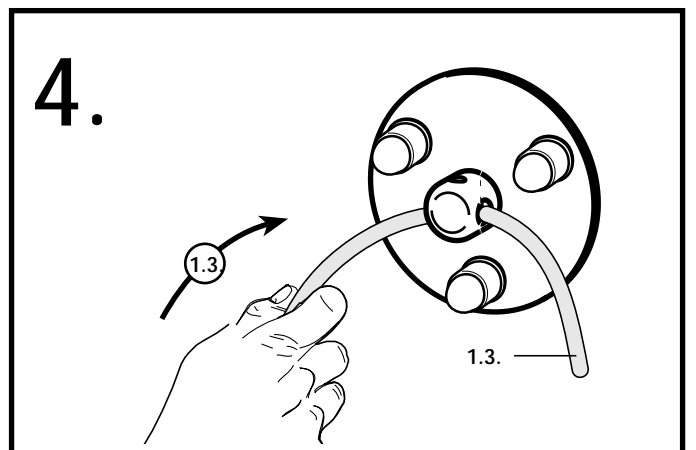
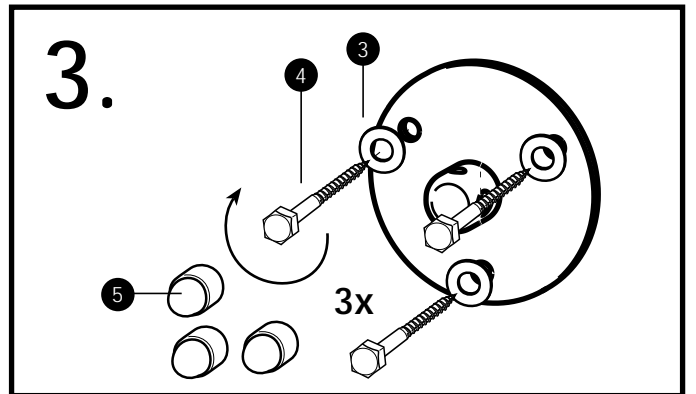
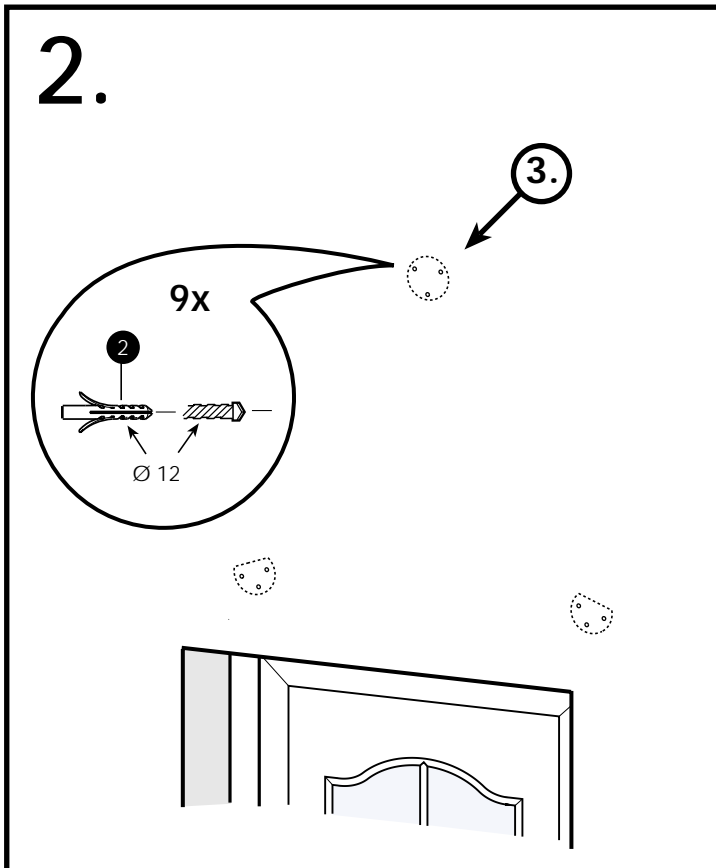
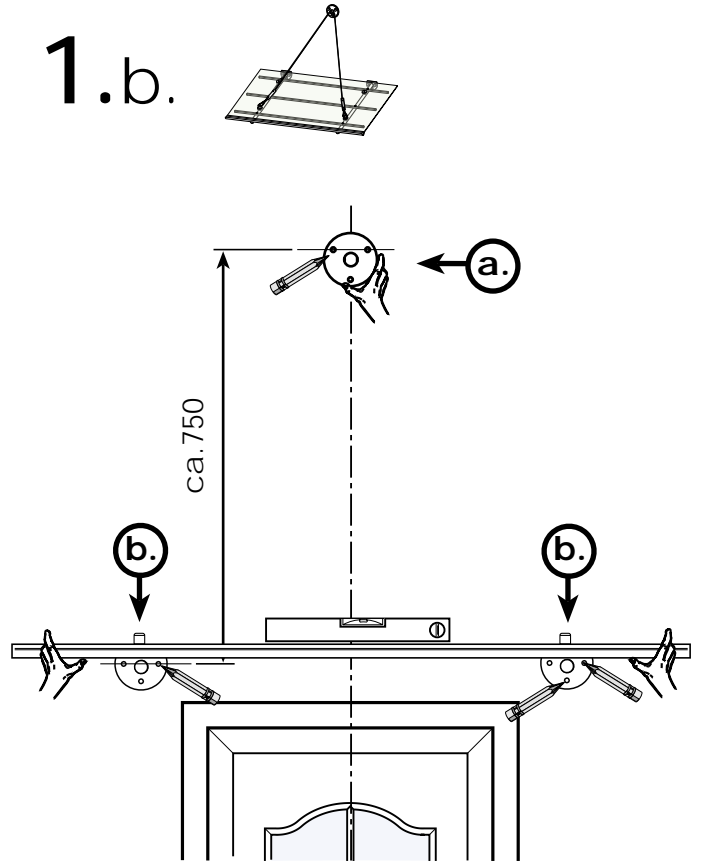
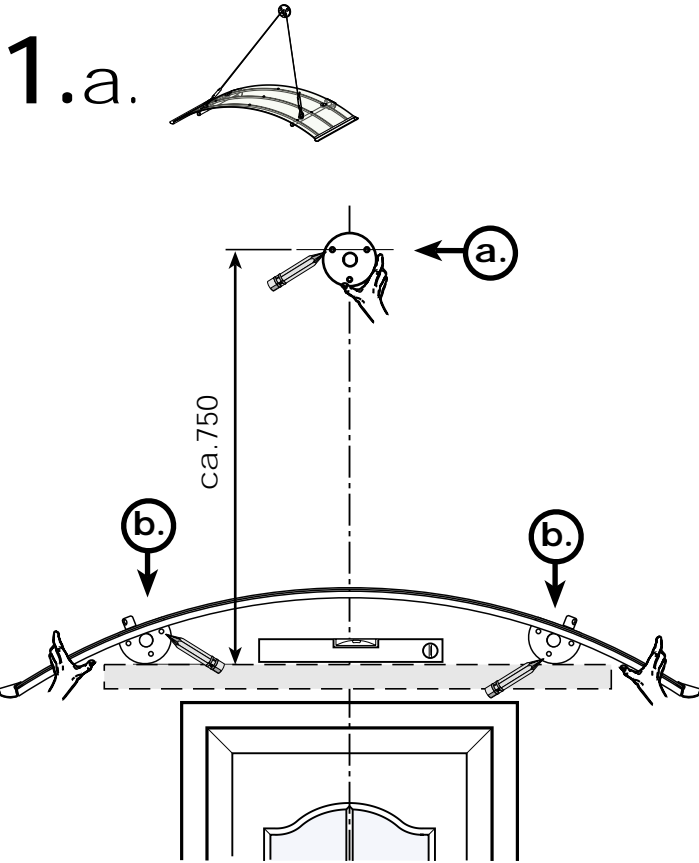

MONTAGEANLEITUNG

5.

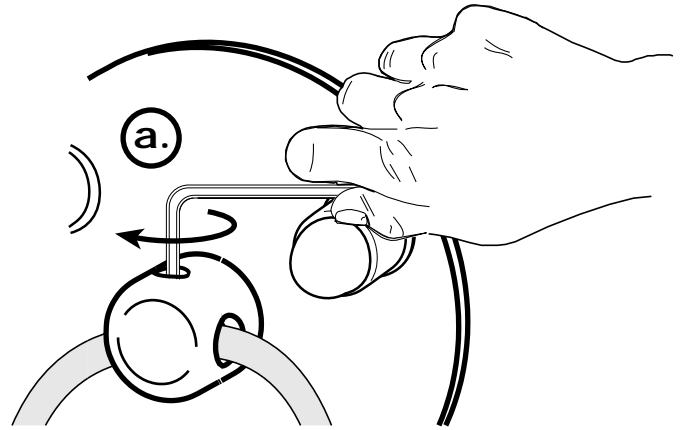
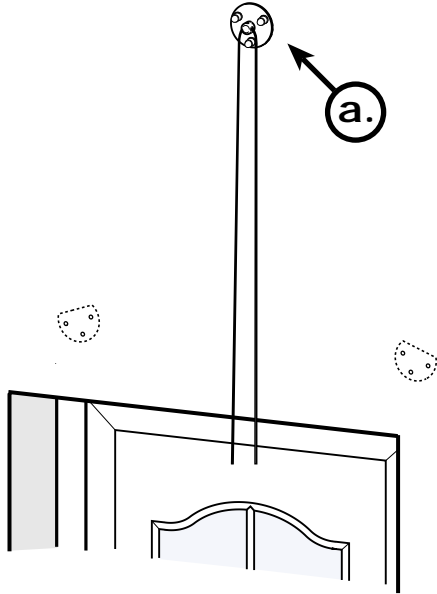

6.

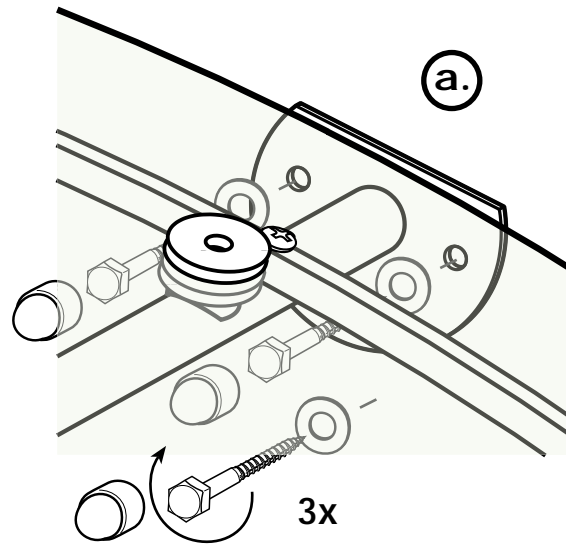
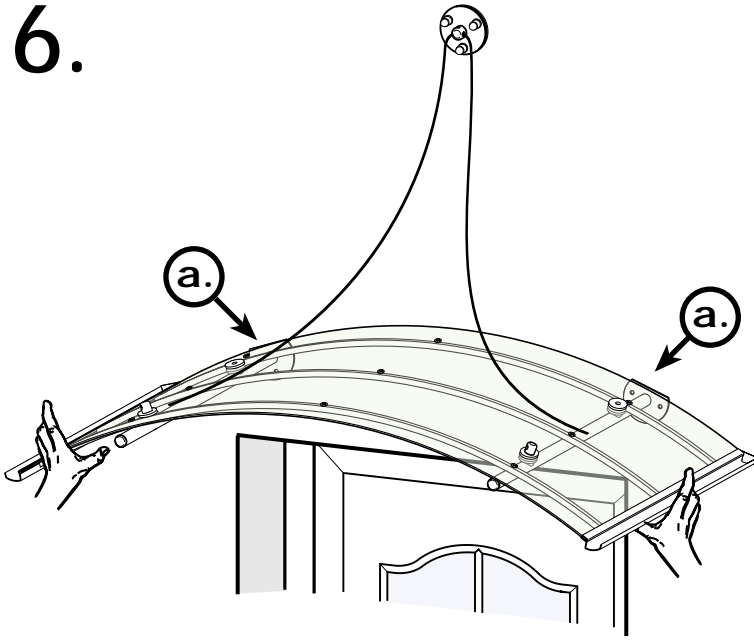



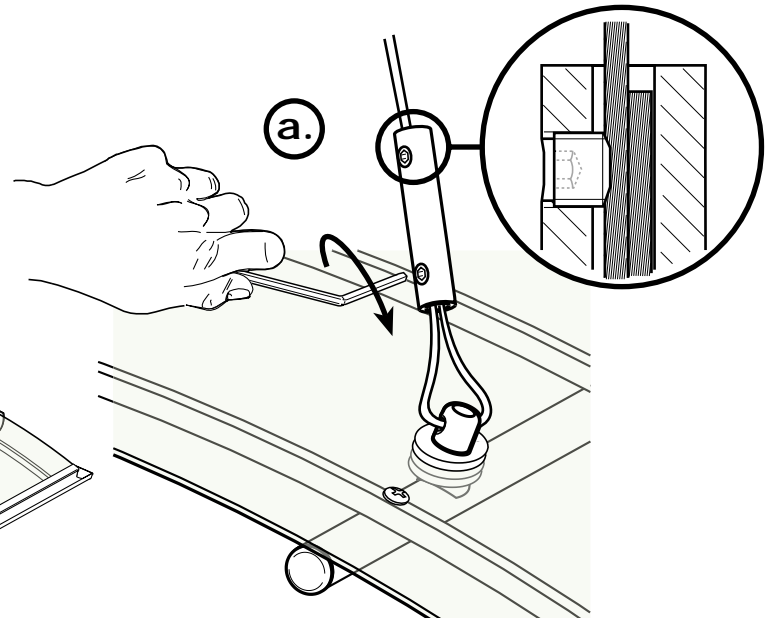
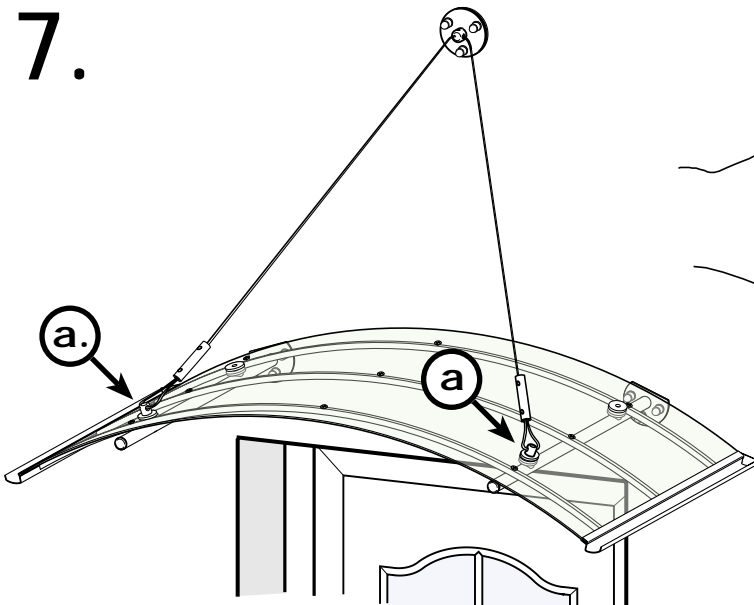





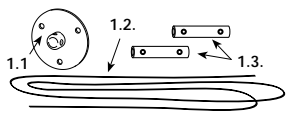



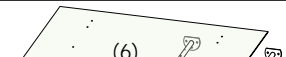



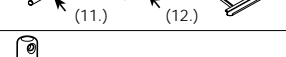
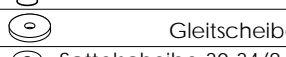

7.



ERSATZTEILAUFRAG: BV-S 160 & PT/S 160

SPARE PARTS ORDER • COMMANDE DE PIÈCES DE RECHANGE • TAGLIANDO DI COMMISSIONE • ONDERDELENBESTELBON • PEDIDO DE PIEZAS DE REPUESTO
 ЗАКАЗ ЗАПАСНЫХ ЧАСТЕЙ • ZAMÓWIENIE CZĘŚCI ZAPASOWYCH • PÓTALKATRÉSZ-MEGRENDELÉS • OBJEDNÁVKA NÁHRADNÍCH DÍLU
 NAROCILO ZA NADOMESTNE DELE • OBJEDNÁVKA NÁHRADNÍCH DÍLOV • NALOG ZA REZERVNE DJELOVE • Narudžba rezervnih dijelova
 Objednávka náhradných dielov • Naročilo nadomestnih delov • VARAOSATIŁAUS

Nr. No. Čís. Szám átevilka C. BR. Nro	Bezeichnung Denominazione Description Beschrijving Descripción Oznaczenie Oznaczenie Naziv Nimitys	Description Beschrijving Descripción Oznaczenie Oznaczenie Naziv Nimitys	Artikel-Nr. Artículo n. Article No. Nr części Cikkszám C. tovaru átevilka artikla komada broj proizvoda Номенклатурный номер Tuotenumero	No. d'article Artikel-Nr. No.de articulo Čís. artiklu C. tovaru átevilka artikla komada broj proizvoda Номенклатурный номер Tuotenumero	Stück Pezzi Quantity Szt Kusú количество Szállított darabszám Del Kappale	Quantité Stuks Piezas Kus	Farbe Couleur Colore Kleur Colour Color Цвет Kolor Barva Szín Barva Farba boja Vári	cm Mera	Menge Quantità Ordered Qty. Cantidad de pedido количество заказываемых частей Objednané množství Ilość zamówionych części Rendelt mennyiség Kolicina Množstvo kolicina Qté.cdée. Aantal Määrä
1.1. 1.2. 1.3.			Seilsystem 400 - 40000002		BV-S 160 1x 2x 1x	PT/S 160 1x 2x 1x			
2.	 Dübel ø12		4 - 0000603		9x	9x	951		
3.	 U-Scheibe 10.5 DIN125		4 - 0000431		9x	9x	980		
4.	 10x80 DIN571		4 - 0000131		9x	9x	980		
5.	 Abdeckkappe Sw 17		400 - 4000033		9x	9x			
(6)	 (6)		Glasplatte -----		---	1x			
(7)	 (7)		Tragarm -----		---	2x			
(8)	 (8)		∅ Rohr 1 - 0881515		---	3x	950		
(9)	 (9)		Glasplatte -----		1x	---			
(10)	 (10)		Rahmen -----		1x	---			
(11.)	 (11.)		Tragarm links -----		1x	---			
(12.)	 (12.)		Tragarm rechts -----		1x	---			
(13)			-----		2x	2x			
(14)	 Gleitscheibe		400 - 4000092		4x	8x	024/085		
(15)	 Sattelscheibe 30-34/8,3		400 - 4000091		2x	4x	952/085		
(16)	 Weich PVC		400 - 4000460		9x	6x	952		
(17)	 5,3 DIN9021		4 - 0000411		9x	6x	983		
(18)	 4,8x13 DIN7981		4 - 0000093		3x	---	980		
(19)	 4,2x32 DIN7981		4 - 0000073		6x	---	983		
(20)	 4,2x32DIN7982		4 - 0000074		---	6x	983		
(21)	 M8x50 DIN7991		4 - 0000995		---	2x	983		
(22)	 M8X70 DIN7991		4 - 0000152		2x	2x	983		

Kundendienst - Telefon 0 26 39 / 921 - 349

Kundendienst - Telefax 0 26 39 / 921 - 175

Montag bis Freitag von 8.00 - 12.00 • 13.00 - 18.00 Uhr

E-Mail kundendienst@dusar.de

- Bei Produktionsmängeln und Ersatzteilbestellungen (siehe Tabelle) bitte an den Kundendienst wenden.
- Bitte Ersatzteilauftrag benutzen. Danke!
- In case of production faults or if you wish to order spare parts (see table) please contact your local trader or the after-sales service.
- Please use the spare-parts order form. Thank you !
- Veillez consulter votre dépositaire ou le service après-vente pour tous défauts du produit ou pour des commandes de pièces de rechange (voir tableau).
- Utilisez le bon de commande de pièces de rechange. Merci !
- Per imperfezioni dei prodotti o per ordinazione di pezzi di ricambio (vedi tabella) si rivolga, per cortesia, al suo rivenditore ossia al suo centro di assistenza.
- Per cortesia, usi il modulo per commisioni pezzi di ricambio. Grazie !
- Bij fabricagefouten en onderdeelbestellingen (zie tabel) wendt U zich tot Uw handelaar respectievelijk Uw klantenservice.
- Onderdelenbestellijst gebruiken a.u.b. Dank U wel !
- En caso de defectos de producción o para efectuar un pedido de piezas de repuesto (véase tabla) sírvase consultar al servicio posventa.
- Sírvase utilizar el formulario de pedido para piezas de repuesto. ¡Muchas gracias!
- Przy składaniu zamówień na części zapasowe prosimy zwrócić się do punktu handlowego w Państwa okolicy.
- Prosimy wykorzystywać następujący formularz na części za pasowe. Dziękujemy.

- С заказами на запчасти просим обращаться в пункты продажи, которые расположены недалеко Вашего места проживания.
- Просим использовать прилагаемый бланк заказа на запасные части. Спасибо за покупку!
- Při objednávaní náhradních dílů se prosím obračete na prodejní oddělení v hlavním městě ve Vaší zemi.
- Následující formulář, prosím, použijte na náhradní díly. Děkujeme.
- A pótkatrészek megrendelésével szíveskedjenek a legközelebbi kereskedelmi egységhez fordulni.
- A pótkatrészek megrendeléséhez az alábbi nyomtatványt kérjük kitölteni. Köszönjük.
- Kod proizvodnih grešaka i kod narudžbi rezervnih djelova (vidi tablicu) molimo da se javite servisu.
- Molimo da koristite obrazac za narudžbu rezervnih djelova. Hvala!
- Pri vžrobných nedostatkoch a objednávkach náhradných dielov (vid tabulku) sa obráťte na servisnú službu.
- Prosim, poučevajte zázakzu pre náhradné diely. Dakujeme!
- Pri tovarniókih napakah in narocanju nadomestnih delov (poglej tabelo) obrnite se, prosim, na servis za stranke.
- Prosim, uporabljajte narocilnico za nadomestne dele. Hvala!

DUSAR[®]

Einer der führenden Hersteller von Duschtabtrennungen, Duschwannen, Badzubehör, Badewannen, Whirlpools und Vordächern.

DUSAR GMBH • INDUSTRIEGEBIET • BUCHENSTRASSE 1 • 56584 ANHAUSEN • TEL +49 (0) 2639 / 921-0 • FAX +49 (0) 2639 / 921-172

INTERNET: www.dusar.de • E-MAIL: info@dusar.de